

CompactGROUND

G10plus

Assembly Instructions

Version: 04
Language: English | Original language: German
Original installation instructions

Important! Read carefully before installation!

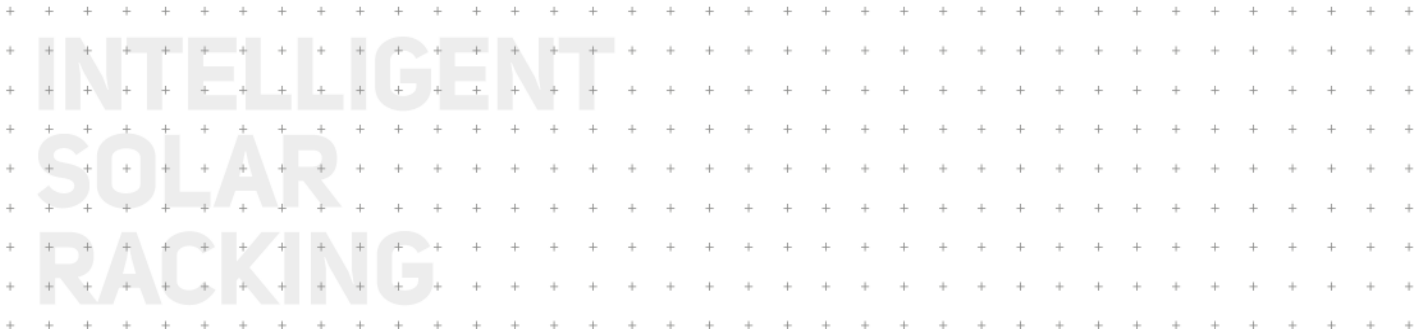

Legal Notice

Subject to changes due to technical improvements. These assembly instructions correspond to the technical status of the delivered product and not to the current development status of the manufacturer.

If pages or parts of the assembly instructions are missing, please contact the manufacturer's address given below.

The original language of these assembly instructions is German. Any assembly instructions in another language are a translation of the assembly instructions in German.

The assembly instructions are protected by copyright. Without written permission from AEROCOMPACT® the assembly instructions may not be copied, reproduced, microfilmed, translated or converted for storage and processing in computer systems, either in part or in full.

Copyright by © AEROCOMPACT®

Manufacturer

AEROCOMPACT® Holding
Sonnenstraße 10
A 6822 Satteins | Austria

office@aerocompact.com
www.aerocompact.com

Update

This manual is subject to change without notice. This does not represent any obligation on the part of the manufacturer.

Creation date

01/2022

TOC

About This Document	5
Applicable Documents	5
Explanation of Symbols	5
Symbols in Illustrations	5
Target group	6
Appropriate use	6
Liability, Warranty, Guarantee	6
Planning documents	6
Guarantee	7
General information on liability	8
Systems with clamping on the short module side	8
 System Overview	 9
Basic components G10plus (E/W)	9
Ballasting	10
Fastening Material	10
Accessories	11
Accessories for grounding / potential equalization (USA)	11
Module Accessories	11
 Assembly	 13
Pre-install the clamps	13
Measure area, place components	14
Installing modules	15
Install the first module row	15
Install the second module row	17
Installing Microinverters (optional)	18
Installing Microinverters - EU (optional)	18
Securing the system	18
Option 1: Securing with ground anchors	19
Option 2: Ballasting directly on the front brackets, middle brackets or connector brackets	19
Option 3: Short ballast tray	19
Option 4: Long ballast tray	20
Install cable pipes (optional)	22
Installing the cable pipe to the ballast tray	22
Fasten the cable pipes with brackets	22
Grounding	23
Install grounding / bonding equipment (not USA-compliant)	23
Install grounding / bonding equipment (USA-compliant)	24
 Maintenance	 26
Complete System	26
Fittings	26
 Dismantling	 27
Disassemble components	27
 Appendix	 28
UL Certification Notes	28



Load Ratings28

plus
10
G1

ABOUT THIS DOCUMENT

These installation instructions describe the procedure for installing the product. Read these assembly instructions carefully before starting the assembly. Follow the instructions carefully to ensure correct installation of the product.

Applicable Documents

The following documents are a part of these installation instructions and are absolutely necessary for the correct assembly of the system:

- Project report from AEROTOOL
- Planning documents and drawings

Explanation of Symbols

In order to make these assembly instructions easy to understand, uniform safety instructions, symbols, terms and abbreviations are used. The following symbols indicate notes which are not relevant to safety, but which make working with the assembly instructions easier.

- Requirements for an action are depicted with this symbol. Make sure that all requirements are met before you carry out the following actions.
- Action steps are depicted with this symbol. Carry out the steps in the specified order.
- The result of the action is depicted with this symbol.

i This note provides useful information for a smooth assembly of the product.

Symbols in Illustrations

Activities

Certain activities are required to carry out the assembly. These activities are shown in the illustrations with the following symbols.



Check AEROTOOL planning documents



Visual inspection



Activity by hand



Observe right angle



Optional component,
optional installation method

Tools

Certain tools are required to carry out the assembly. These tools are shown in the illustrations with the following symbols.



Measuring tape, measure



Cordless screwdriver, screwdriver



Pencil, mark



Torque wrench,
Observe torque



Chalk line



Drilling machine, drill

Target group

These installation instructions are intended for trained personnel who are familiar with the installation of photovoltaic systems. The personnel should also be familiar with working on roofs and know the local regulations regarding work safety. The personnel must also observe the instructions in the Safety chapter.

Appropriate use

The CompactGROUND ground-mounted system is designed for installing PV modules on the ground. The slope must not exceed 10° (ballasting with ballast stones and/or ground screws). A project specific clarification is required for a slope inclination of more than 10°. The system must be properly installed in accordance with these installation instructions and the planning documents supplied.

PV modules used with the CompactGROUND system should be approved by the module manufacturer. AEROCOMPACT accepts no liability for loss of performance or damage of any kind to the PV modules.

Any other use of the CompactGROUND system is considered improper.

Liability, Warranty, Guarantee

These assembly instructions and the project report supplied with the product are integral parts of the product. The information, data and instructions given in the assembly instructions were up to date at the time of printing. No claims can be made for products already delivered that deviate from the information, illustrations and descriptions.

The project report supplied with the system contains the static calculation related to the location. The position of the modules on the ground, the number and position of the ground screws and/or ballasting must be followed exactly as specified in the project report. The Aerocompact system is designed and planned with the Aerotool software.

Planning documents

Before installation, check that the site conditions correspond to the planning document details.

This includes:

- The site
- The surroundings and the topography of the site
- Dimensions, surface and ground composition
- Position and size of obstacles (terrain levels, existing or planned pipeline routes, traffic routes and other structures, etc.)
- Drainage features
- Site preparation, i.e. grading, if necessary

If in doubt, measure the friction between the system components and the ground surface to validate the assumptions made in the design documents. If the project details in the planning documents do not match the values on-site, contact the responsible planner. This is especially true if the planning is not based on detailed and up-to-date data collection on-site.

Ensure that the weight and dimensions of the ballast blocks are in accordance with the planning documents. The ballast plans from AEROTOOL are optimized for specific block characteristics. If the block specified in the design report is not used, then a revised ballast plan will be needed.

The selection and procurement of the ballast blocks must be handled by the customer. Ensure that the ballast blocks have sufficient density to remain stable under local conditions over the lifetime of the PV system.

Before using ground screws, ensure that their entire length can be permanently anchored in the ground. Caution against the following should be taken:

- Hazards from contaminated sites
- Increased risk of corrosion due to high groundwater level and/or aggressive soil chemistry (strongly acidic or alkaline reaction).
- Restrictions on anchorage depth, e.g. in the soil depth above the cap of a landfill, excessive content of stones and boulders (which may require pre-drilling).

If the anchorage depth is limited, a shorter ground screw with a length of 10 inches (280 mm) can be used instead of the standard 18 inch (460 mm) ground screw. If a shorter ground screw (lower load capacity) must be used in place of the standard ground screw, then a new statics plan is required.

Aerocompact accepts no liability for damage and malfunctions caused by:

- improper use
- use of non-certified components.
- unauthorized modifications to the product.
- improper handling of the product.
- Installation errors
- Failure to comply with the installation instructions or planning documents.

Guarantee

The warranty period for the system is 25 years. The warranty period for galvanized steel parts is 10 years. The guarantee is only valid if the installation is carried out professionally and all system components are purchased from Aerocompact. If the assembly instructions or the planning documents are disregarded, the warranty will be invalidated.

Photovoltaic racking systems are not maintenance-free. Carry out maintenance annually and immediately after unusual weather events, e.g., after heavy storms or heavy snowfall, etc. If the maintenance is not carried out at the specified interval, the warranty will become void.

General information on liability

The ground mount system is sold within the framework of a purchase agreement. Assembly/installation by the purchaser or third parties is not carried out on behalf of or for Aerocompact and must be carried out by qualified personnel strictly in accordance with the installation instructions. The Aerocompact system must be designed and planned with the AEROTOOL software. Aerocompact is not responsible for the project-related construction of the ground or ground surface or for its professional execution.

Errors and damage as well as limited or insufficient functionality of the system due to incorrect installation and/or installation that deviates from the installation instructions and/or the project report (AEROTOOL) exclude any material defect for which Aerocompact is responsible. In the event of improper handling, the rights of the buyer due to a material defect shall expire. The system warranty is only valid if all system components are purchased from Aerocompact.

Each change must be approved by the responsible planner. Unauthorized deviations from the plans will result in loss of warranty and exclusion of liability in the event of property damage or personal injury.

Systems with clamping on the short module side

For a system with a clamp on the short side of the module, it is assumed that the module may also be used in this mounting form (clamp on the short sides of the module). This approval can either be generally available as part of the module certification or, under certain circumstances, can also be given by the module manufacturer on a project-specific basis.

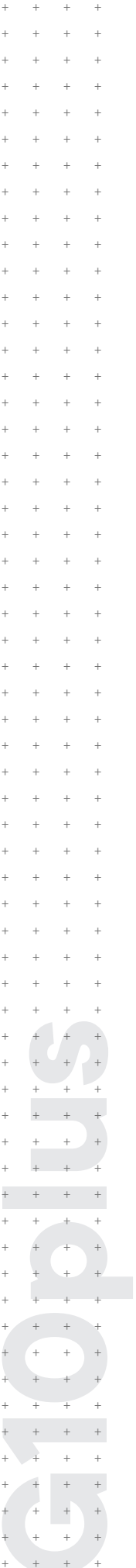

SYSTEM OVERVIEW

Basic components G10plus (E/W)

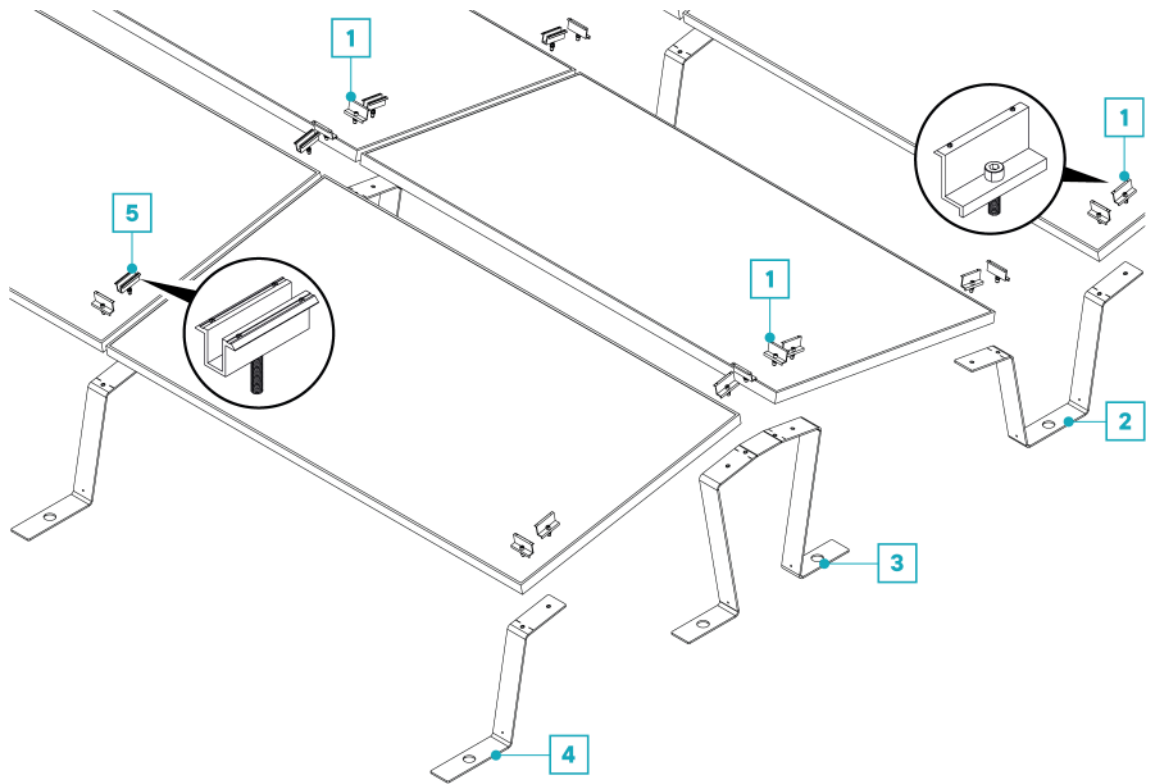

- 1** End clamp, varying clamp height for 30 - 50 mm frame heights | CLEG10-XX
- 2** Connector | G10+CN
- 3** Center support | G10+MB
- 4** Front foot | G10+FB
- 5** Middle clamp, for 30 - 50 mm frame height | CLMG10

Ballasting

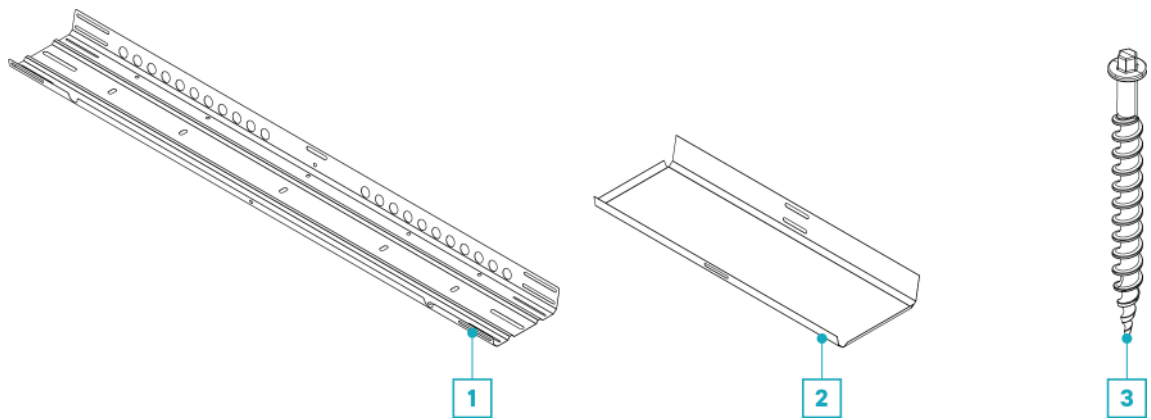

- 1** Long ballast tray | BT-1800, BT-2050, BT-2300
- 2** Short ballast tray | BT-880
- 3** Ground Screw 18 in. | GSC 1.75 in.x18 in.

Fastening Material

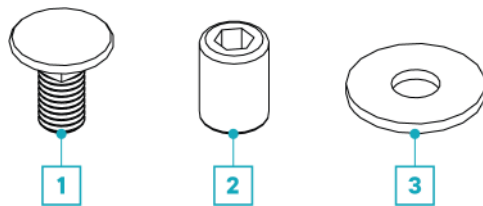

- 1** Carriage Bolt M8x20 | CB8x20
- 2** Allen Nut M8x16 | AN8x16
- 3** Flat Washer 8.4/30 | FW8.4/30

Accessories

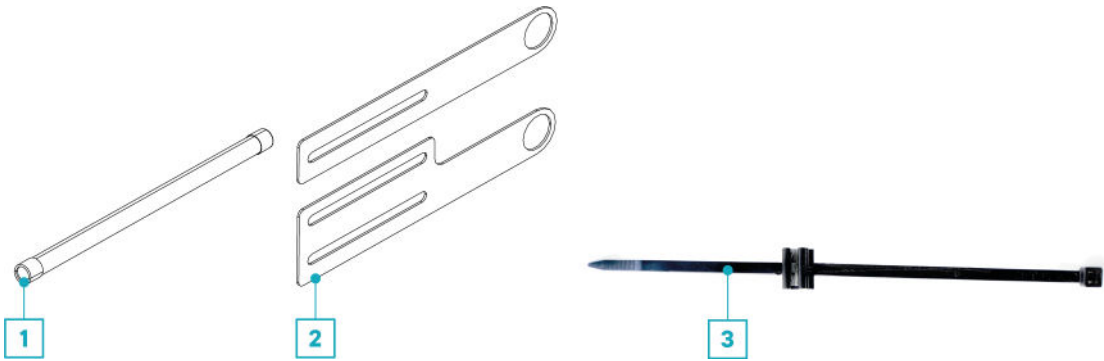

- 1 Cable conduit | CP-430, CP-620, CP-840
- 2 Bracket for cable conduit | BR-CP
- 3 Cable tie clip to module | CLP-M

Accessories for grounding / potential equalization (USA)

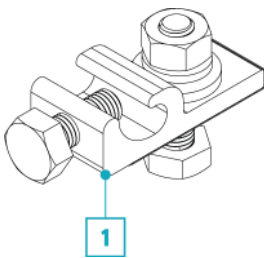

- 1 Grounding lug with nut (follows UL 476 or UL 2703 requirements) | GL18N

Module Accessories

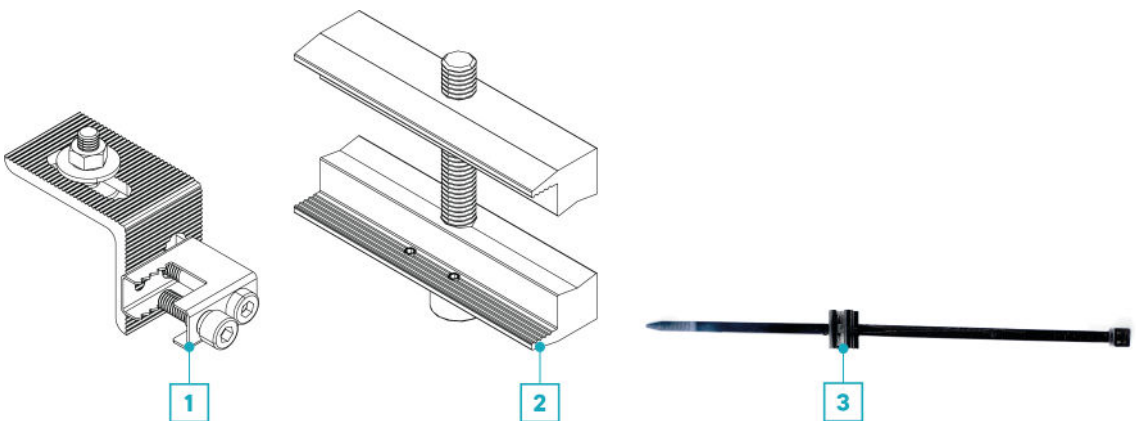

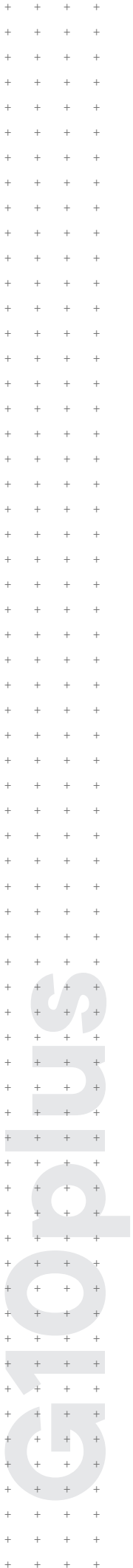

- 1** Holder for module accessories, Mounting bracket for microinverter (EU) | MA-BR
- 2** Holder for module accessories, Microinverter clamp US | MA-MO
- 3** Cable tie clip to module | CLP-M

Measure area, place components

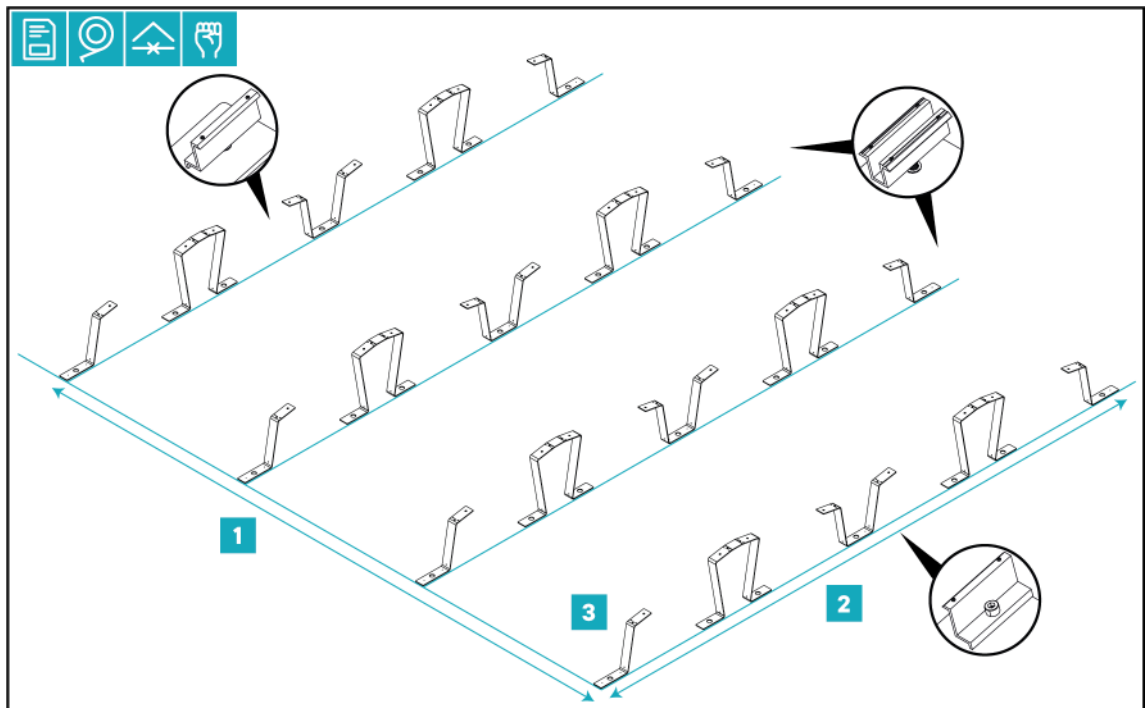

- ▶ Take the dimensions of the array field from the planning documents.
- ▶ Measure the length of the module field **1** and mark the line.
- ▶ Measure the width of the module field **2** and mark the line.
- ▶ Place the front brackets, middle brackets and connector brackets in the array field **3**:
 Edge rows: place front brackets, middle brackets and connector brackets with end-clamps pre-installed.
 Middle rows: place front brackets, middle brackets and connector brackets with mid-clamps pre-installed.

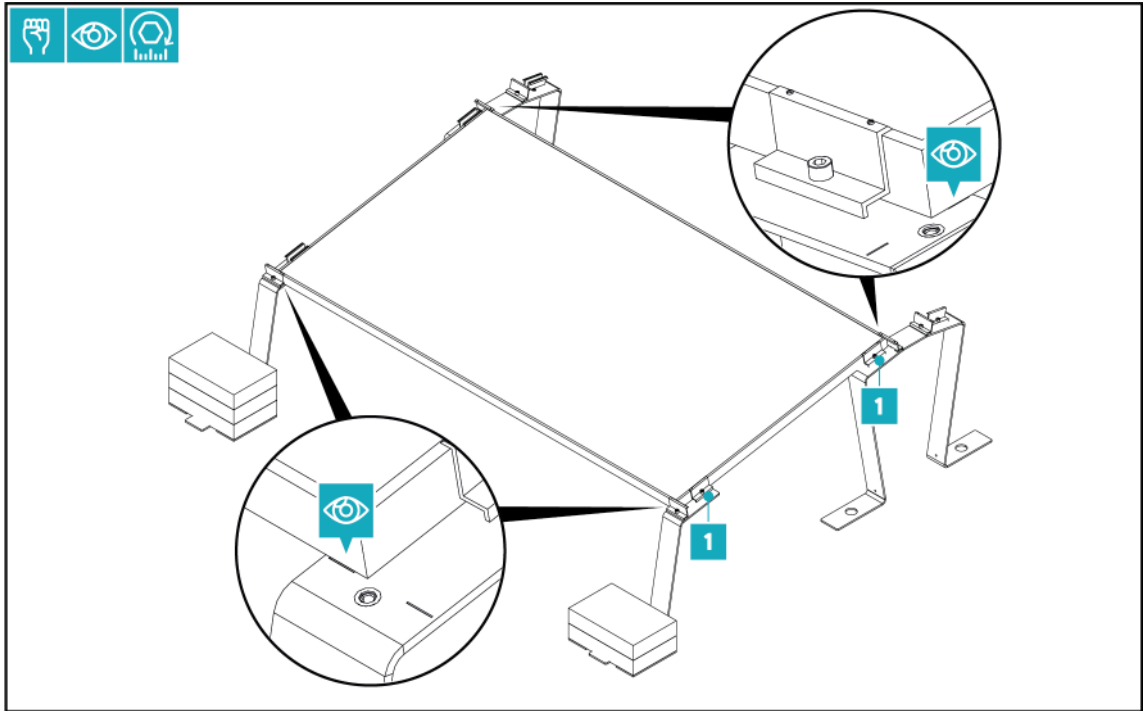

- Align each module with the marks on the front brackets/ middle brackets.
- Tighten the screws of the side end-clamps **1** to 15 Nm or 11 ft lbs.

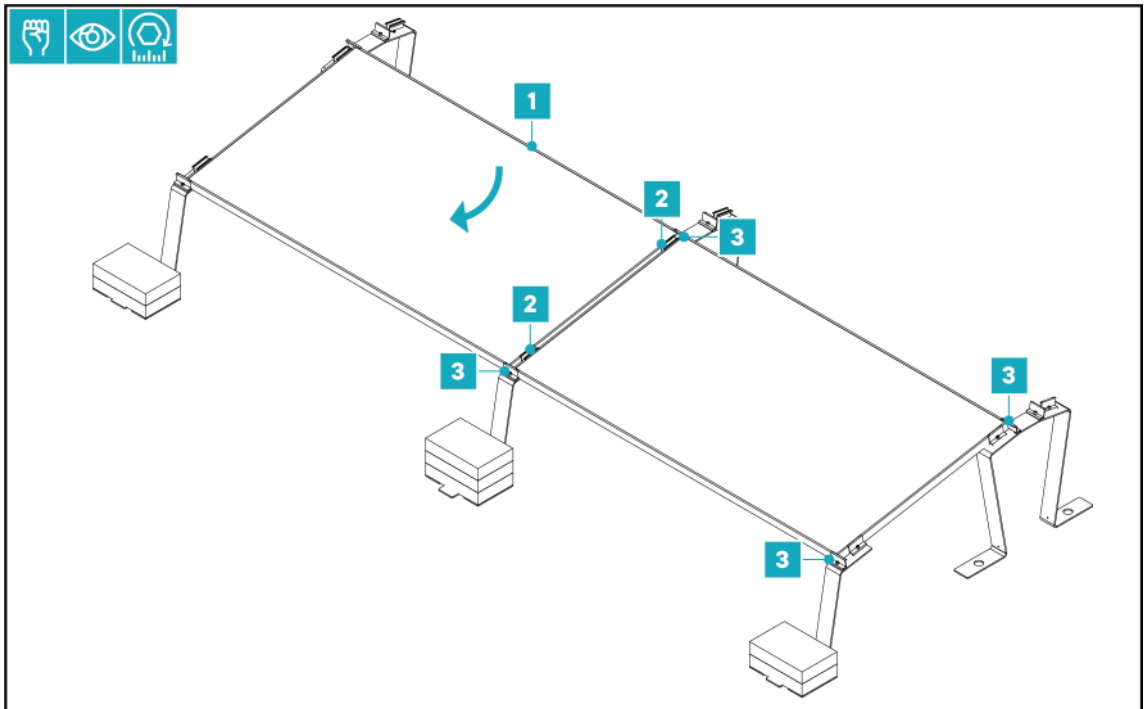

- Place the next module **1**.
- Tighten the screws of the mid-clamps **2** of the previous module with 15 Nm or 11 ft lbs.
- Tighten the screws of the end-clamps **3** at the bottom of the modules to 15 Nm or 11 ft lbs.

snipus
G10

Install the second module row

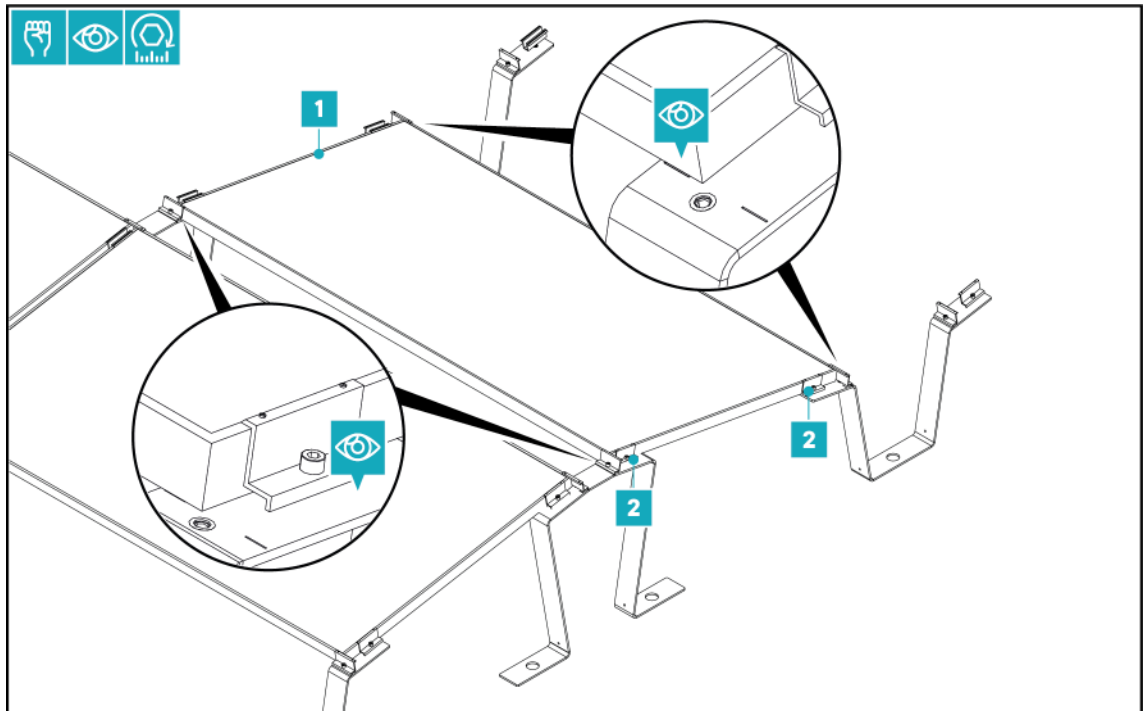

- ▶ Place the module **1** on the middle brackets and connector brackets.
- ▶ Align each module with the marks on the middle brackets/ connector brackets.
- ▶ Tighten the screws of the end-clamps with 15 Nm or 11 ft lbs. **2**
- ▶ Install remaining modules as in the first row.

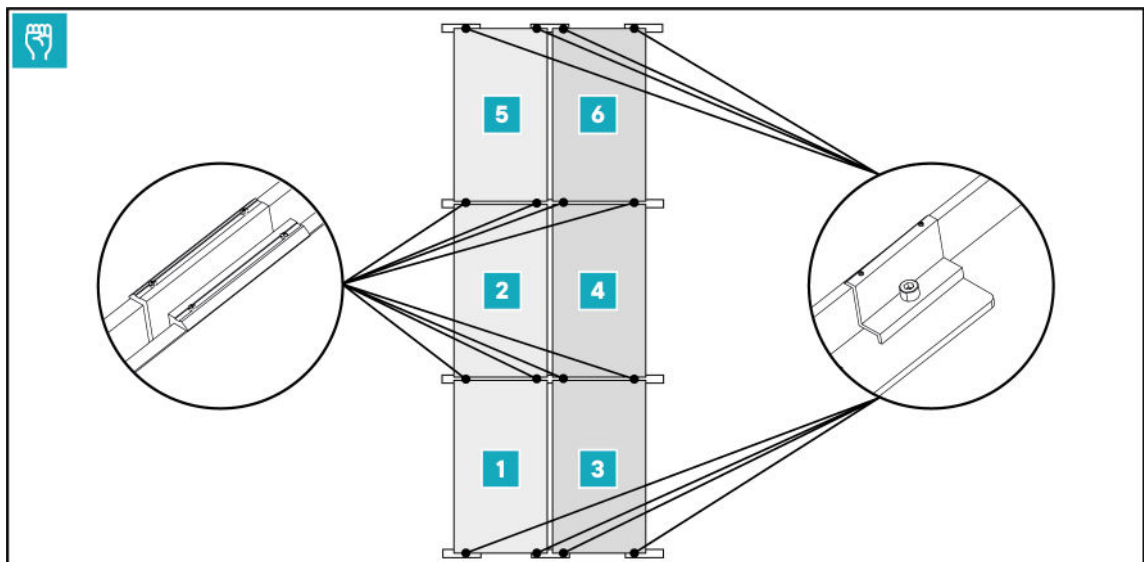

- ▶ Install other modules in the recommended order.
- ▶ Tighten all end-clamps and mid-clamps to 15 Nm or 11 ft lbs.

plus
 10
 G10

Installing Microinverters (optional)

i The microinverter can be mounted directly onto the module frame.

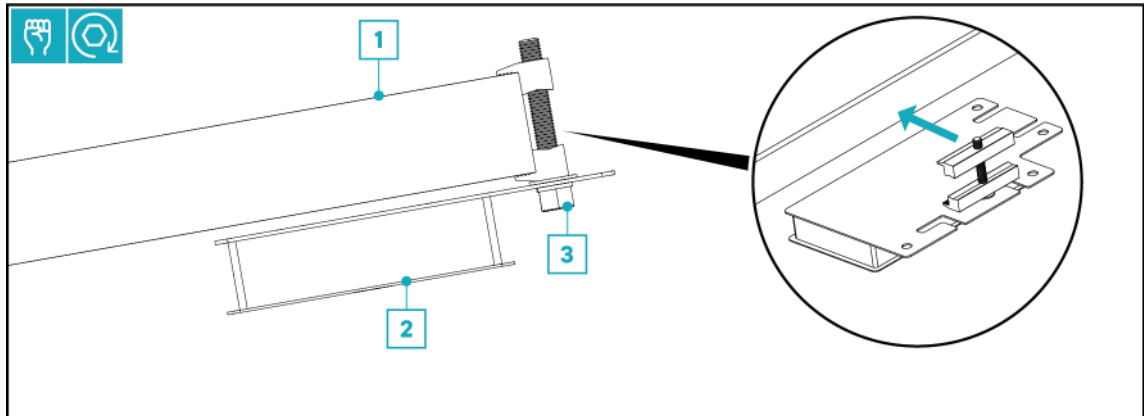

- Observe the manufacturer's installation instructions (PV module, microinverter).
- Attach the microinverter with the microinverter clamp **2** to the module frame **1**.
- Carefully tighten the bolt **3** until the clamp is firmly attached to the module frame.

Installing Microinverters - EU (optional)

i The microinverter can be mounted below the module on a bracket, connector bracket or support.

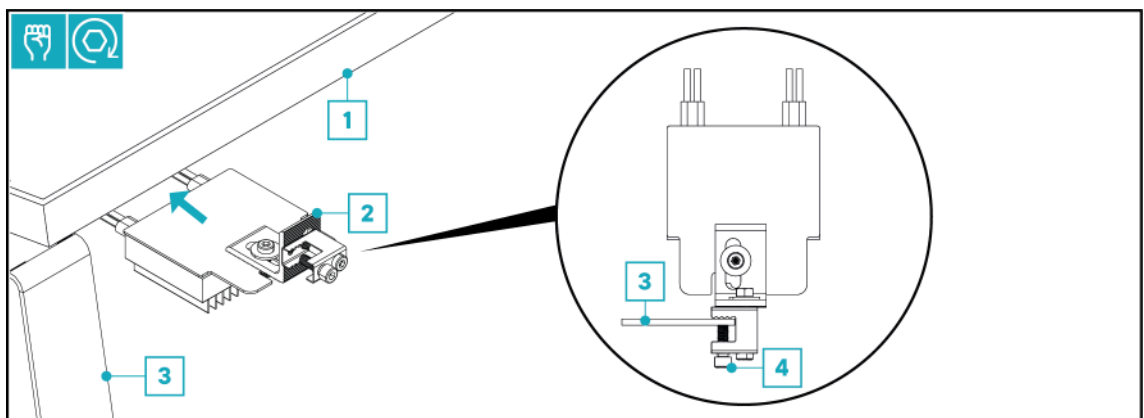

- Install the microinverter on the microinverter-bracket according to the manufacturer's specifications.
- Place installed microinverter **2** on the bracket, connector bracket or support **3** below the module **1**.
- Attach the microinverter-bracket to the bracket, connector bracket or support **3** and hand-tighten the Allen screw **4**.

Securing the system

i Depending on the circumstances, the system can be secured in various ways.

Install cable pipes (optional)

i The cable pipes can be installed at the edges or interior of the module field.

i Depending on the situation, the cable pipes can be installed with the brackets provided or on the long ballast tray.

Installing the cable pipe to the ballast tray

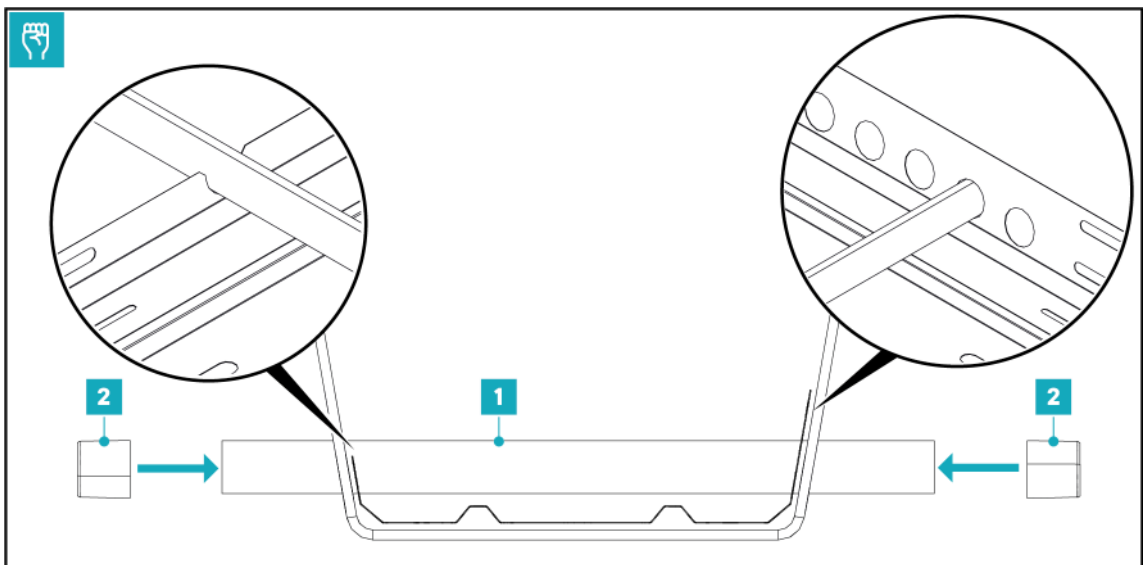

- ▶ Slide the cable pipe **1** through the appropriate hole in the ballast tray.
- ▶ Attach the plastic caps **2** to the end of the cable pipe.

Fasten the cable pipes with brackets

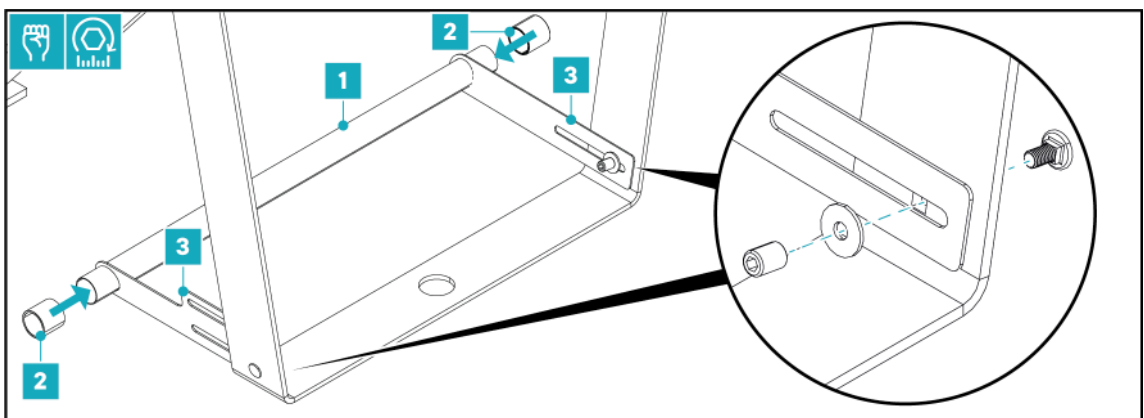

- ▶ Slide the cable pipe through the brackets **1**.
- ▶ Attach the plastic caps **2** to the end of the cable pipe.
- ▶ Screw the brackets to the connector bracket **3**.
- ▶ Tighten the screws with 15 Nm or 11 ft lb.

snipus
 10plus
 G10

MAINTENANCE

To prevent personal injury and property damage, the system must be inspected regularly by qualified personnel. The operator of the equipment must perform the following maintenance items once a year.

A test of the system is necessary after severe weather events (e.g. wind storm, snow, hail, etc.) as well as after extreme events such as a hurricane or earthquake.

Complete System

- ▶ Check all components of the system for damage.
- ▶ Replace damaged components as soon as possible.

Fittings

- ▶ Check all screw connections.
- ▶ Tighten loose screw connections. Confirm the tightening torque according to the assembly instructions.



DISMANTLING

Disassemble components

▶ Disassembling the system: Carry out the assembly steps in reverse order.

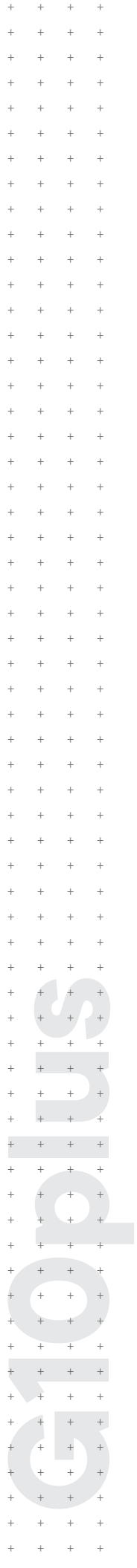

APPENDIX

UL Certification Notes

The CompactGROUND G systems are certified by SolarPTL for grounding/bonding and mechanical loading. SolarPTL, LLC is a Nationally Recognized Testing Laboratory (NRTL).

The CompactGROUND G grounding method conforms to ANSI/UL 2703, is approved for use with photovoltaic modules listed under ANSI/UL 1703 and/or ANSI/UL 61730, whichever applies, and complies with the National Electrical Code, ANSI/NFPA 70. The individual parts within the solar array need to be electrically bonded to existing DC ground paths via the use of a UL 467 approved grounding lug. The conductor size, type and temperature rating should be selected in accordance with NEC 690.45 and NEC 250.122.1. The primary evaluation for grounding and/or mounting was performed with the PV module type(s) listed below.

- o KPV ME 310 Projekt
- o KPV ME NEC 360 mono

Specific evaluations of other modules can be provided upon request and at cost (a minimum of two modules are required).

Load Ratings

The CompactGROUND G15, G20, G25, and G10+ system design load ratings for a 72 cell PV module are:

- o Upward: 22.3 psf / 1.1 kPa
- o Downward: 22.3 psf / 1.1 kPa
- o Down-slope 5.8 psf / 0.3 kPa

Tested loads:

- o Upward: 33.4 psf / 1.6 kPa
- o Downward: 33.4 psf / 1.6 kPa
- o Down-slope 8.6 psf / 0.4 kPa