

SunDanzer^{DC-Powered Refrigeration}

DC-Powered Refrigerator & Freezer Model 160 User's Manual



SunDanzer
420 E Aviation Drive Suite 130
Tucson, AZ, 85714 USA

INTRODUCTION

Congratulations! You have purchased one of the most efficient refrigeration products available on the market today. The **SunDanzer™** chest freezers and chest refrigerators are designed to provide years of efficient trouble-free operation. The design is optimized for energy savings with an efficient DC compressor, thick insulation, and a chest style configuration.

Before using the appliance, read through this manual carefully including all the information on safety, installation, operation, and cleaning. These guidelines do not cover every possible condition or situation that may occur. Be safe using common sense and caution when installing, operating and cleaning this appliance. If you are unsure about any of these instructions or warnings, contact SunDanzer or your local product dealer for assistance.

CRITICAL INFORMATION

- ◆ **IF THE APPLIANCE HAS BEEN HANDLED ON ITS SIDE OR STANDING ON END, IT SHOULD BE ALLOWED TO SIT IN THE NORMAL OPERATING POSITION FOR 24 HOURS BEFORE TURNING IT ON.**
- ◆ **BEFORE ADDING FOOD, ALLOW THIS APPLIANCE TO RUN FOR AT LEAST 20 MINUTES.**
- ◆ **THIS APPLIANCE OPERATES ON 12 OR 24 VOLTS DC (DIRECT CURRENT) ONLY! DO NOT CONNECT DIRECTLY TO AN AC (ALTERNATING CURRENT) POWER SOURCE.**
- ◆ **NEVER USE EXCESSIVE FORCE ON THE HANDLE TO OPEN THE LID.**
- ◆ **IF THE UNIT DOES NOT START AND COOL ONCE INSTALLED, CHECK THE WIRING AND CONNECTIONS FOR GOOD CONDUCTIVITY. THIS IS THE #1 SERVICE ISSUE.**

IMPORTANT SAFETY INSTRUCTIONS

Prior to Installation

At the delivery, please check that the appliance is complete and has not been damaged during transport. It is not advised to connect an appliance that has been damaged, especially damage to the electrical supply cable or refrigerant circuit. In the event of damage please contact SunDanzer or your local product dealer for assistance.

General Safety

- Before cleaning or repositioning the appliance, always disconnect from the electrical power supply.
- Service the appliance only if you are a trained or authorized refrigeration technician.
- Do not use other electrical appliances (such as ice cream makers) inside of this appliance.
- Do not store any containers with flammable or toxic vapors or liquids in or around the appliance, such as organic solvents, spray cans, gas cans, etc.

Servicing

- Unauthorized work may void the warranty.

INSTALLATION

Unpacking and Cleaning

Remove all packaging and securing tapes from the appliance. To avoid injury and damage to the appliance, be extremely cautious when using sharp or pointed tools to complete this task. You may want to leave the lid open allowing the compartment to ventilate for 20-30 minutes to get rid of residual odors.

Positioning

- The skin of the refrigerator is the condenser and will become warm when the compressor is running. There should be adequate ventilation space between the refrigerator and neighboring walls. At least 3 inches (7.5 cm) is recommended. Never add insulation to the exterior of the appliance.
- For best efficiency, place the refrigerator in a cool location and avoid prolonged direct sunlight on the appliance.
- Always keep the air vent openings of the compressor housing cover (Lower right side or rear) free from dust and obstructions.

Leveling

Leveling is not required for proper operation of this unit. However, some units have adjustable feet if leveling is desired.

Installing the door handle

Some models may ship without the door handle installed. If this is the case, the handle and mounting hardware will be located inside the refrigerator.

Electrical Connection

- Always keep the air vent openings of the compressor housing cover (Lower right side or rear) free from dust and obstructions.
- The positive wire is colored Red or is black with a red stripe. The negative wire is black.
- **THE APPLIANCE MUST BE CONNECTED TO A 12V OR 24 VDC POWER SOURCE ONLY**, such as a battery or charge controller. The unit will automatically operate on either 12 or 24 VDC. User does not need to make any adjustment.
- This unit will not operate directly from a PV solar module. Contact SunDanzer if you prefer this option.
- If the polarity is reversed, the unit will not be damaged, but will not run. If the unit is equipped with a light, the light will operate even with reverse polarity.
- Since there is no established standard DC plug, the power cord has bare terminations. The user must provide a meaning of connection this wire to the power source. Using wire nuts, or adding a ring or spade terminal is common.
- This connection should not become hot when the units is running. If it does, rework the connection to insure better conductivity.

Electronics Diagram (Direct Battery connection example)

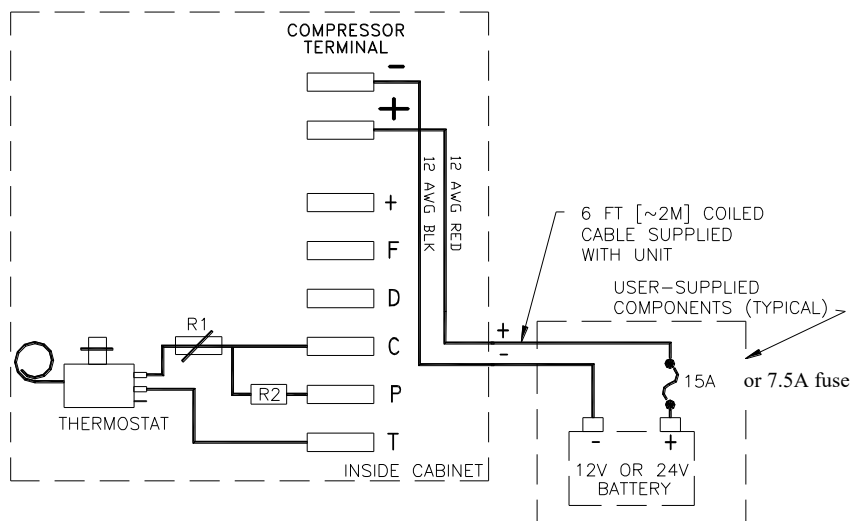

Fuse

A fuse is required in order to protect the wiring. A standard automobile fuse is recommended, and the fuse should be wired to the positive (“+”) side of the system close to the positive battery terminal. For 12V operation, use a 15A fuse, and for 24V operation use a 7.5A fuse.

Operating Voltage	Fuse
12V	15A
24V	7.5A

ATTENTION: A 6 ft. (2 m) power cord is supplied. If a longer connection cable is necessary, the cable cross section (or gauge) must be equal to or greater than the cable sizes recommended on the following table.

Cable Size		12V Cable Length		24V Cable Length	
Area	AWG	m	ft.	m	ft.
mm ²	Gauge				
2.5	12	2.5	8	5	16
4	12	4	13	8	26
6	10	6	19.5	12	39
10	8	10	32.8	20	65.6

The most common customer call is related to using inadequate wiring such that the compressor will experience a low voltage situation at start-up and not run.

Low Voltage Disconnect

The compressor electronics include a low voltage disconnect feature. If the input voltage to the appliance falls below 9.6V (in 12 V mode) or 21.3V (in 24 V mode), the compressor will shut-off. Once the voltage increases above 10.9V (in 12V mode) or 22.6V (in 24V mode), the compressor will resume normal operation.

This feature is designed to protect the system battery from experiencing too low a depth of discharge.

	12V Operation	24V Operation
Cut- in	9.6V	21.3V
Cut - out	10.9V	22.7V

Compatible Solar System

The unit is designed to run from a 12 or 24V DC power source such as a deep cycle or solar battery. The battery is typically charged using wind or solar PV power. The energy required to run the SunDanzer fridges and freezer is listed on the website. In general, the refrigerator models require 120-200 W-hr/day in a 32°C ambient. Freezer models require 300-600 W-hr/day.

OPERATION

Starting the Appliance

Once the wiring is complete and the refrigerator has 12 or 24VDC available, the unit will turn on automatically. The thermostat is also an on/off switch for the unit. When the dial is fully counter clockwise, the fridge will be off. The compressor is very quiet and it may be difficult to hear it running.

Initial Cooldown

Once on, the refrigerator will reach operating temperature in about 20 to 40 minutes. Once it is cold, you may add food, but if a large quantity (> 5kg) of warm food is added, it may take hours to cool.

Ambient Temperature/Climate

This refrigerator is designed to operate in an ambient temperature range of (5°C) to 110°F° (43°C). It can operate outside this range, but with reduced reliability.

Temperature Control

The temperature within the appliance is controlled by a mechanical thermostat situated on the lower front or side of the cabinet. When you first start the appliance, we suggest that you turn the thermostat to a medium setting. The best way to measure the average internal temperature is to measure the temperature of a bottle of water located near the middle of the refrigerator. The normal operating temperature of a refrigerator is 39°F (4°C) and the normal operating temperature of a freezer is -5° to +10°F (-21° to -12°C). The refrigerator will draw noticeably less power at warmer settings.



Opening and Closing the Lid

The lid is fitted with a uniform sealing strip to prevent warm air and moisture from entering the appliance compartment. Be sure that the lid seal is free from obstructions and forms a complete seal around the rim of the cabinet. Overfilling and/or unlevel installation of the appliance will prevent a good seal. It might be hard to open the lid immediately after the lid is closed. This is due to a vacuum which is created after warm air entering the refrigerator cools and contracts after the door is closed. This pressure difference will equalize in a few seconds.

Loading

Do not over fill! Leave some space at the top so the door can always fully close. To assist the cabinet in cooling large loads quicker, keep the cabinet full of product (or containers of water). It will also help to cool your food quicker if your food is packaged in smaller containers rather than large ones. It is best to never package food more than 5cm (2 in.) thick. The center of food packaged thicker than this will cool slowly and may spoil. Leave air spaces between food items for quicker cooling. Items in contact with the interior walls will cool faster and can freeze if the thermostat is set to a colder setting.

Baskets

The DC160 includes three baskets.

Door Lock

The DC160 units are fitted with a door lock. Keys for the lock will be located inside the fridge. If the lock need to be replaced, contact SunDanzer or an authorized SunDanzer dealer for replacement parts.

Shutting down or taking unit Out of Service

Turning the thermostat fully country clockwise will turn the unit off. If the unit is to be off for an extended period (more than 6 hours), the interior should be thoroughly cleaned and dried. It is recommended to leave the lid slightly open to provide ventilation.

DEFROSTING (Freezer models only)

- Before any cleaning or repositioning is carried out, you must **DISCONNECT** the appliance from the electrical power supply.
- Transfer the cold food to a cooler or simple box to keep it cold during the defrosting.

Freezer Defrosting

The appliance compartment will become progressively covered with frost. This should be removed periodically with a plastic scraper (provided with some units). However, when the ice becomes very thick on the interior walls, complete defrosting should be carried out. Perform this operation when the appliance is empty and disconnected from the power supply.

To
1

Never use sharp metal tools to scrape or chip off frost from the interior compartment as this could damage the appliance beyond repair. Do not use heat sources, such as electric or gas heaters to complete the defrost process.

2. Remove any stored food and store in coolers, or wrap in several layers of newspaper and store in a cool place.
3. Leave the lid open.
4. Remove the plug from the defrost water drain located in the bottom interior of the cabinet.
5. To accelerate the defrosting process, place a bowl of hot (not boiling) water inside of the appliance and close the lid.
6. The defrost water can be collected by placing a pan under the defrost drain located on the exterior bottom front of the cabinet.
7. When defrosting is complete, wash and dry the interior thoroughly. Be sure to replace the plug on the defrost water drain.
8. Reconnect the appliance to the electrical supply and leave running (while empty) for at least 2 hours allowing the interior to cool sufficiently.
9. Replace the previously removed foodstuff.

ATTENTION: A rise in temperature of frozen food products during defrosting may shorten their safe storage life.

CLEANING AND MAINTENANCE

Scheduled Maintenance and Preventative Maintenance

There is no scheduled or preventative maintenance with the SunDanzer chest products, simply clean as required.

Internal Cleaning

Wash the inside of the appliance with luke warm water and a mild soap. Never use abrasive or corrosive cleaning agents, steel wool, scouring sponges, chemical cleaning agents, or highly perfumed cleaning products to clean the interior as these will damage the surface and leave behind a strong odor. A sponge, towel, or soft brush is recommended. Washing with a mixture of two table spoons of baking soda to 1 quart (1.14L) warm water. After cleaning, thoroughly rinse and dry.

External Cleaning

Wash the outside of the cabinet with warm water and a mild soap or detergent. Do not use abrasive or corrosive cleaning agents, chemical cleaning agents, steel wool or scouring sponges to complete this task as it may cause damage to the surfaces.

Interior Light

Units are equipped with a non-serviceable interior LED light.

HINTS & TIPS

Normal Operating Sounds

- A thermostat controls the compressor and you may hear a 'click' when the thermostat cuts in and out.
- You may hear faint gurgling or bubbling sounds when the refrigerant is pumped through the refrigerant coils.
- The compressor is quiet and can only be heard in a quiet room.

Energy Saving Advice

- Do not install the appliance close to sources of heat, such as a stove, boiler, heater, chimney, etc, and avoid exposure of the appliance to direct sunlight.
- Also allow adequate spacing around the cabinet for air circulation (3in. or 7.5cm)'Warmer thermostat setting require less energy to maintain
- Avoid unnecessary frosting in the cabinet by packing all food and liquids in airtight packages or containers.
- Always keep foodstuff stored in tightly sealed packaging or containers, and allow some space for air to circulate around each item.
- Avoid keeping the lid open for extended periods of time or opening the lid too frequently as warm air will enter the cabinet and cause the compressor run unnecessarily often.
- Ensure there are no obstructions preventing the lid from closing properly and forming a tight seal.

TROUBLE SHOOTING

Before contacting a service technician, SunDanzer or your local product dealer, check the following points.

If you call out a technician to a fault listed below, or to repair a fault caused by misuse, abuse, or faulty installation, a charge will be made even if the appliance is under warranty.

SYMPTOM	SOLUTION
Appliance connected to power, but does not operate	<ul style="list-style-type: none"> • Check if 12 or 24V DC is present at the appliance. If not check all connections and the system battery voltage. • Check that the polarity is correct “+” is connected to “+” and “-“ to “-“. • Check the fuse. If blown, replace with a new one. • <u>The main common problem with installations is voltage drop to the compressor which causes the unit to fail to start due to “Low Voltage.” Typically, a connection is not as tight as it should be, or the wire size to the compressor is too small. The low voltage problem occurs at the instant of start-up and is sometimes difficult to detect with a volt meter because the event is very quick (<100 ms)</u>
Appliance is operating, but the interior is not cold.	<ul style="list-style-type: none"> • It may take 20 minutes for the interior of the cabinet to become cool. • Check that the thermostat control knob is turned to the correct setting relevant to room/ambient temperatures. • Has too much warm foodstuff recently been placed in the cabinet? If so, it is normal to not be cold and it will take time to return to temperature. • Does the cabinet have adequate ventilation around the side walls allowing it to transfer heat properly? (See Installation Section). • If the compressor is running and the unit does not cool, then it is most likely low on refrigerant.
Appliance is running too cold.	<ul style="list-style-type: none"> • Is the thermostat set too cold? • Turn the thermostat back and forth as this might correct the problem, but order a replacement thermostat. • Is the thermostat capillary tube fully inserted in the holder? This requires removing the compressor compartment cover to inspect. When the thermostat is properly inserted, you will feel hard stop which indicates the capillary is fully inserted. • If the ambient temperature is colder than the refrigerator set-point, the refrigerator will eventually become too cold. There is no heater in the refrigerator.
Lid will not open	<ul style="list-style-type: none"> • Has the lid just been opened? If so, wait 10-20 seconds for the air pressure to equalize and try again.
Light will not turn on	<ul style="list-style-type: none"> • If the interior light (if present) does not turn on, check to see if the refrigerator is receiving power. If it is, the light need to be replaced.
Door light flickers	<ul style="list-style-type: none"> • This is a known issue when you tap on the lid and does not affect the operation or energy efficiency of the unit.
Water on interior floor	<ul style="list-style-type: none"> • This is normal. Wipe dry with a cloth or paper towel.
Water on floor near fridge	<ul style="list-style-type: none"> • The condensate drain is equipped with a drain cap. If this cap is removed, water will leak from the fridge to the floor around the fridge. If the drain cap becomes lost, find a suitable plug to close the drain hole. If the cap is missing, the energy consumption and rate of moisture build-up will increase.
Condensate around the door seal.	<ul style="list-style-type: none"> • If there is condensate around the door seal, check the door to make sure the seal is fully closing and not damaged or blocked.
Excessive frost and ice has built up.	<ul style="list-style-type: none"> • Is the weather hot and humid? If so, this will increase the rate of frost build up in the cabinet. • Ensure that foodstuff is properly packaged. • Check that the lid is closed and has a good seal, and that nothing is preventing the lid from closing properly. • Large quantities of food have recently been placed in the cabinet/and or the lid is frequently opened. • Ensure that advised periodic cleaning has been carried out.

Fault Indicator light

Some models include a fault indicator light on the compressor. This light can be seen through the side or rear cover without removing the cover. The number of blinks indicates the type of fault. The following is a table of the fault code meanings. This table applies to units with a SECOP compressor.

Blinks	Fault Description
1	Battery protection cut-out
2	Too many start attempts of fan over current
3	Motor start error
4	Minimum motor speed error
5	ECU Thermal cut-out
6	Thermostat error

Customer Responsibilities

The following items are the responsibility of the customer and are not covered in the warranty:

- Proper care and use of the appliance as described in this manual.
- Damage to the interior or exterior finish or components after delivery.
- Proper power supply, fuse, wiring, and connections.
- Service required as a result of alteration, misuse, abuse, flooding, fire, lightning, or acts of God.

END OF LIFE

While this refrigerator should last many years, at some point it will be time to dispose of the unit. Be sure to use normal and proper disposal methods based on your local. When disposing of your appliance, use an authorized disposal site. The refrigerant must be completely drained and collected by an authorized technician for recycling prior to disposal. Check with your local Environmental Agency for recommendations on recycling this appliance in your area. Remove the electrical connection wiring.

SPARE PARTS

Please contact SunDanzer with the part description for replacement parts.

- BD35 Compressor, PN 101Z0203, or
- BD50 Compressor, PN 101Z0204
- ECU, PN 101N0212
- Standard thermostat: 077B0028 (Fridge) or 077B0022 (freezer)

WARRANTY

SUNDANZER WARRANTS, TO THE ORIGINAL OWNER, THAT THIS PRODUCT IS FREE FROM DEFECTS IN WORKMANSHIP AND MATERIAL FOR A PERIOD OF TWO YEAR FROM THE PURCHASE DATE. THIS WARRANTY SHALL BE LIMITED TO REPAIRING OR REPLACING, AT SUNDANZER'S OPTION AND WITHOUT CHARGE TO THE PURCHASER, DEFECTIVE COMPONENTS. ALL WARRANTY WORK SHALL BE PERFORMED AT A SUNDANZER APPROVED FACILITY. SHIPPING CHARGES RELATED TO RETURNING THE PRODUCT TO THE SUNDANZER FACILITY ARE NOT COVERED UNDER THIS WARRANTY. HOWEVER, THIS WARRANTY COVERS SHIPPING CHARGES RELATED TO RETURNING THE REPAIRED PRODUCT TO THE CUSTOMER WITHIN THE CONTINENTAL UNITED STATES. OUTSIDE THE CONTINENTAL UNITED STATES, ALL SHIPPING CHARGES ARE THE RESPONSIBILITY OF THE CUSTOMER AND ARE NOT COVERED BY THIS WARRANTY. THIS WARRANTY DOES NOT APPLY TO DAMAGE OR WEAR TO THE PRODUCT CAUSED BY ACCIDENT, ABUSE, MISUSE, NEGLIGENCE, UNAUTHORIZED ALTERATION OR REPAIR, OR IF THE PRODUCT WAS NOT INSTALLED IN ACCORDANCE WITH SUNDANZER PRINTED INSTALLATION AND OPERATING INSTRUCTIONS. TO OBTAIN SERVICE UNDER THIS WARRANTY, THE DEFECTIVE PRODUCT MUST BE RETURNED TO SUNDANZER TOGETHER WITH A RETURN MATERIAL AUTHORIZATION (RMA) NUMBER. ANY PRODUCT REPAIRED OR REPLACED UNDER THIS WARRANTY WILL BE WARRANTED FOR THE BALANCE OF THE WARRANTY PERIOD WITH RESPECT TO THE ORIGINAL PURCHASED PRODUCT. SUNDANZER WILL NOT BE LIABLE FOR ANY INCIDENTAL OR CONSEQUENTIAL DAMAGES, LOSSES, OR EXPENSES ARISING FROM INSTALLATION, USE OR ANY OTHER CAUSES. THERE ARE NO EXPRESS OR IMPLIED WARRANTIES, INCLUDING MERCHANTABILITY OR FITNESS FOR A PARTICULAR PURPOSE, WHICH EXTEND BEYOND THOSE WARRANTIES DESCRIBED OR REFERRED TO ABOVE.

For warranty claims or additional information, contact:

SunDanzer

420 E Aviation Drive Suite 130
Tucson, AZ, 85714 USA
Phone: 520-882-9100
Fax: 775-201-0236
Email: info@sundanzer.com
Website: www.sundanzer.com

Record Product Information:

Model Number:

Serial Number: _____

Purchase Date: _____

Thank you for buying SunDanzer!