

SunDanzer^{DC-Powered Refrigeration}

DC-Powered Refrigerator & Freezer DC100 Manual



SunDanzer
420 E Aviation Drive Suite 130
Tucson, AZ, 85714 USA

INTRODUCTION

Congratulations! You have purchased one of the most efficient refrigeration products available on the market today. The **SunDanzer™** chest freezers and chest refrigerators are designed to provide years of efficient trouble-free operation. The design is optimized for energy savings with an efficient DC compressor, thick insulation, and a chest style configuration.

Before using the appliance, read through this manual carefully including all the information on safety, installation, operation, and cleaning. These guidelines do not cover every possible condition or situation that may occur. Be safe using common sense and caution when installing, operating and cleaning this appliance. If you are unsure about any of these instructions or warnings, contact SunDanzer or your local product dealer for assistance.

IMPORTANT NOTES

- ◆ **THIS APPLIANCE SHOULD BE LEFT OFF IN ITS NORMAL OPERATING POSITION FOR 2 HOURS PRIOR TO TURNING IT ON TO ALLOW THE COMPRESSOR OIL TO SETTLE.**
- ◆ **IF THE APPLIANCE HAS BEEN HANDLED ON ITS SIDE OR STANDING ON END, IT SHOULD BE ALLOWED TO SIT IN THE NORMAL OPERATING POSITION FOR 12 HOURS BEFORE TURNING IT ON.**
- ◆ **PRIOR TO ADDING FOODSTUFF, THIS APPLIANCE SHOULD BE RUN FOR AT LEAST 4 HOURS ALLOWING THE INERIOR OF THE CABINET TO COOL.**
- ◆ **THIS APPLIANCE OPERATES ON 12 OR 24 VOLTS DC (DIRECT CURRENT) ONLY! DO NOT CONNECT DIRECTLY TO AN AC (ALTERNATING CURRENT) POWER SOURCE.**
- ◆ **THIS APPLIANCE IS DESIGNED FOR DOMESTIC USE ONLY!** Specifically for the storage of edible/consumable food and drinks (foodstuff). It is not intended for commercial or industrial use.
- ◆ **NEVER USE EXCESSIVE FORCE ON THE HANDLE TO OPEN THE LID.**
- ◆ If the room/ambient temperature approaches the appliance operating temperature, the appliance will not function as it should. If the room/ambient temperature exceeds 100°F (38°C), the appliance will not function as it should.
- ◆ A battery-powered refrigerator or freezer has a cooling capacity lower than typical AC units. Because the compressor is small, the unit runs more efficiently, but lacks the ability to cool large warm loads as quickly as typical AC appliances.

IMPORTANT SAFETY INSTRUCTIONS

These warnings are provided in the interests of your safety. Please ensure that you understand them all before installing or using this appliance. Your safety is of paramount importance. If you are unsure about any of these meanings or warnings, contact SunDanzer or your local product dealer for assistance.

Prior to Installation

- At the delivery, please check that the appliance is complete and has not been damaged during transport. It is not advised to connect an appliance that has been damaged, especially damage to the electrical supply cable or refrigerant circuit. In the event of damage please contact SunDanzer or your local product dealer for assistance.

General Safety

- Before cleaning or repositioning the appliance, always disconnect from the electrical power supply.
- Service the appliance only if you are a trained or authorized refrigeration technician.
- This appliance contains refrigerant R-134a and a polyol-ester compressor oil in its refrigerant circuit. Take utmost care when handling your appliance so as to not cause damage to the refrigerant circuit with consequent possible leakage.
- Do not use other electrical appliances (such as ice cream makers) inside of the refrigerating appliance.

Child Safety

- **There is a DANGER OF SUFFOCATION if a child becomes trapped inside!**
- Keep children from playing in, on, or around this appliance.
- When the unit is not in use, please secure or remove the lid to prevent children from playing inside the cabinet.
- **Keep children away from the packaging material. DANGER OF SUFFOCATION!**

Installation

- This appliance is heavy. Care should be taken when moving it.
- **This appliance operates on 12 or 24 Volts DC (Direct Current) only!**
- **Under no circumstances should this appliance be directly connected to an AC (Alternating Current) power source.**
- Be sure that the appliance does not stand on the electrical supply cable. Also, be sure the electrical cable is not squeezed or bent when the appliance is being installed or moved.
- Installation work and adjustments on the appliance must be carried out by qualified personnel only. Work performed by persons with inadequate technical knowledge may adversely effect the performance of the appliance, causing damage to the equipment, and void the warranty.
- It is dangerous to make alterations or attempt to modify this product in any way. Product alterations will void the warranty.

During Use

- **This appliance is designed for domestic use only!** Specifically, for the storage of food and drinks (foodstuff). This appliance is not designed for commercial or industrial use.
- Do not store any containers with flammable vapors or liquids in or around the appliance, such as organic solvents, spray cans, gas cans, etc. **Danger of explosion!**

Cleaning

- Before cleaning always disconnect from the electrical power supply.

Servicing

- This product should be serviced by an authorized technician and only genuine spare parts should be used.
- Under no circumstances should you attempt to repair the appliance yourself. Repairs carried out by inexperienced persons may cause injury or serious malfunctioning of the appliance. Unauthorized work may void the warranty.

INSTALLATION

Unpacking and Cleaning

Remove all packaging and securing tapes from the appliance. To avoid injury and causing damage to the appliance, be extremely cautious when using sharp or pointed tools to complete this task. **Keep children away from the packaging material. DANGER OF SUFFOCATION!** Wash the inside and outside of the appliance with luke warm water and a mild soap or detergent. Abrasive or corrosive cleaning agents, steel wool, scouring sponges, or chemical cleaning agents should not be used under any circumstances. A sponge, soft brush or towel is recommended. After cleaning, thoroughly rinse and dry. You may want to leave the lid open allowing the compartment to ventilate for 20-30 minutes to get rid of residual odors. Check with your local Environmental Agency for recommendations on recycling packaging materials in your area.

Positioning

- **IMPORTANT:** The skin of the refrigerator is the condenser and will become warm when the compressor is running. There should be adequate ventilation space between the refrigerator and neighboring walls. At least 3 inches (7.5 cm) is recommended.
- For best efficiency, place the refrigerator in a cool location and avoid prolonged direct sunlight on the appliance.
- Level the refrigerator using the adjustable feet or wood shims if necessary. This is necessary for the thermostat to function properly and for condensation to drain correctly.
- Always keep the air vent openings of the compressor housing cover (Lower right side or rear) free from dust and obstructions.

Installing the door handle

Some models may ship without the door handle installed. If this is the case, the handle and mounting hardware will be located inside the refrigerator.

Let oil settle

- The appliance should be left off for 30 minutes after positioning before it is turned on, to allow the refrigerant oil to settle.
- If the appliance has been handled standing on its side or on end, it should be allowed to stand in the normal operating position for 24 hours before turning it on.

ELECTRICAL DC CONNECTION

- **The positive wire is colored Red or is black with a red stripe. The negative wire is black.**
- **THE APPLIANCE MUST BE CONNECTED TO A 12V OR 24 VDC POWER SOURCE ONLY**, such as a battery or charge controller. The unit will automatically operate on either 12 or 24 VDC. The user does not need to make any adjustment.
- This unit will not operate directly from a PV solar module. Contact SunDanzer if you prefer this option.
- **THIS APPLIANCE MUST NEVER BE CONNECTED DIRECTLY TO ANY AC (Alternating Current) POWER SOURCE!**
- **If the polarity is reversed, the unit will not be damaged, but will not run. If the unit is equipped with a light, the light will operate even with reverse polarity**
- **Since there is no established standard DC plug, the power cord has simple ferrel terminations. The user must provide a meaning of connection this wire to the power source. Using wire nuts, or adding a ring or spade terminal is common.**
- **This connection should not become hot when the units is running. If it does, rework the connection to insure better conductivity.**

BEFORE SWITCHING ON, LET COMPRESSOR OIL SETTLE

- The appliance should be left off for 2 hours after positioning before it is turned on, in order to allow the refrigerant oil to settle.

- If the appliance has been handled standing on its side or on end, it should be allowed to stand in the normal operating position for 12 hours before turning it on.

Electronics Diagram (Direct Battery connection example)

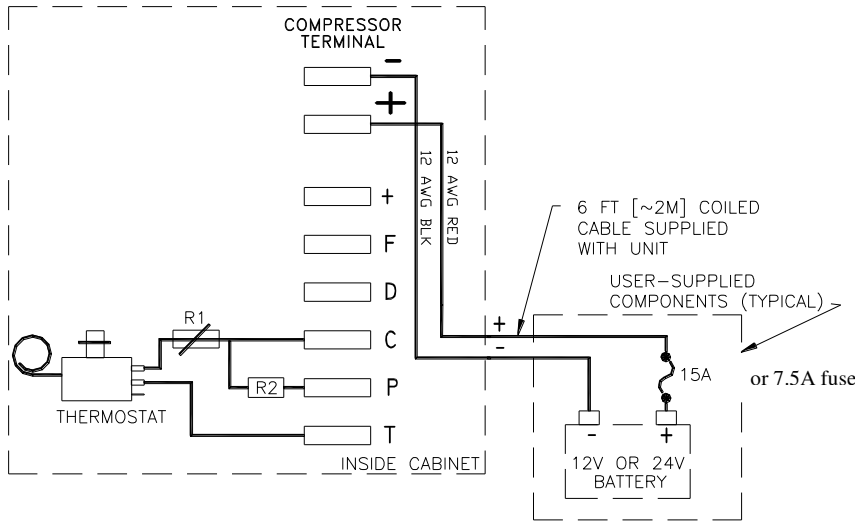

Fuse

A fuse is required in order to protect the wiring. A standard automobile fuse is recommended and the fuse should be wired to the positive (“+”) side of the system close to the positive battery terminal. For 12V operation, use a 15A fuse, and for 24V operation use a 7.5A fuse.

Operating Voltage	Fuse
12V	15A
24V	7.5A

ATTENTION: A 6 ft. (2 m) power cord is supplied. If a longer connection cable is necessary, the cable cross section (or gauge) must be equal to or greater than the cable sizes recommended on the following table.

Cable Size		12V Cable Length		24V Cable Length	
Area	AWG				
mm ²	Gauge	m	ft.	m	ft.
2.5	12	2.5	8	5	16
4	12	4	13	8	26
6	10	6	19.5	12	39
10	8	10	32.8	20	65.6

The most common customer call is related to using inadequate wiring such that the compressor will experiences a low voltage situation at start-up and not run.

Low Voltage Disconnect

The compressor electronics includes a low voltage disconnect feature. If the input voltage to the appliance falls below 9.6V (in 12 V mode) or 21.3V (in 24 V mode), the compressor will shut-off. Once the voltage increases above 10.9V (in 12V mode) or 22.6V (in 24V mode), the compressor will resume normal operation.

This feature is designed to protect the system battery from experiencing too low a depth of discharge.

	12V Operation	24V Operation
Cut- in	9.6V	21.3V
Cut - out	10.9V	22.7V

OPERATION

Once the wiring is complete and the refrigerator has 12 or 24VDC available, the unit will turn on automatically. The thermostat is also an on/off switch for the unit. When the dial is fully counter clockwise, the fridge will be off.

Initial Cooldown

Once on, the refrigerator will reach operating temperature in about 20 minutes. We recommend letting the fridge run at least 30 minutes before placing food or beverage inside. Large warm loads can take hours to cool.

Ambient Temperature/Climate

This refrigerator is designed to operate in a wide ambient temperature range. The certified range is 41F (5C) to 110F (43C).

Starting the Appliance

After the appliance has been properly connected to the 12 or 24 VDC power source, the compressor will automatically turn on and the cabinet will begin cooling. **Allow the cabinet to cool for at least 1 hours prior to adding foodstuff.** To save energy and reduce cost, the units do not have running lights.

Baskets

Larger models include baskets. These baskets can be configured to hang from the top lip of the refrigerator or can stack in the bottom by adjusting the plastic tabs on the baskets.

Temperature Control

The temperature within the appliance is controlled by the thermostat situated on the lower front or side of the cabinet. When you first start the appliance, we suggest that you turn the thermostat to a medium setting. On some models, a coin can be used to turn the dial. The best way to measure the average internal temperature is to measure the temperature of a bottle of water located near the middle of the refrigerator. 39F (4C) is a normal operating temperature. The refrigerator will draw noticeably less power at warmer settings. A good initial operating position of the thermostat is nearer the warm end of the range.



Normal Operating Temperatures

Setting = Warmest	42°F	5°C
Setting = Coldest	30°F	-1°C

The unit will run a colder at high elevations.

Adjustments

As the ambient temperature changes from summer to winter, it may be necessary to adjust the thermostat to achieve the proper internal temperature setting. If the room/ambient temperature approaches the appliance's internal operating temperature, the appliance will not function as it should.

Opening and Closing the Lid

The lid is fitted with a uniform sealing strip to prevent warm air and moisture from entering the appliance compartment. Be sure that the lid and the lid seal is free from obstructions and forms a complete seal around the rim of the cabinet. Overfilling and/or unlevel installation of the appliance will prevent a good seal. It might be hard to open the lid immediately after the lid is closed. This is due to air contraction in the cabinet. This pressure difference will equalize in a few seconds.

Loading

Do not over fill! Leave some space at the top so the door can always fully close. To assist the cabinet in cooling large loads quicker, keep the cabinet full of product (or containers of water). It will also help to cool your food quicker if your food is packaged in smaller containers rather than large ones. Food packages more than 2 inches (5cm) thick will cool slowly. Leave air spaces between food items for quicker cooling. Items in contact with the interior walls will cool much faster and can freeze at if the thermostat is set to the coldest setting.

Shutting down or taking unit Out of Service

Turning the thermostat fully country clockwise will turn the unit off. If the unit is to be off for an extended period (more than 6 hours), the interior should be thoroughly cleaned and dried. It is recommended to leave the lid slightly open to provide ventilation.

DEFROSTING (In freezer models only)

- Before any cleaning or repositioning is carried out, you must **DISCONNECT** the appliance from the electrical power supply.

Freezer Defrosting

The appliance compartment will become progressively covered with frost. This should be removed periodically with a plastic scraper (provided with some units). However, when the ice becomes very thick on the interior walls, complete defrosting should be carried out. Perform this operation when the appliance is empty and disconnected from the power supply.

Never use sharp metal tools to scrape or chip off frost from the interior compartment as this could damage the appliance beyond repair. Do not use heat sources, such as electric or gas heaters to complete the defrost process.

To carry out complete defrosting:

1. Disconnect the appliance from the electrical supply.
2. Remove any stored food and store in coolers, or wrap in several layers of newspaper and store in a cool place.
3. Leave the lid open.
4. Remove the plug from the defrost water drain located in the bottom interior of the cabinet.
5. To accelerate the defrosting process, place a bowl of hot (not boiling) water inside of the appliance and close the lid.
6. The defrost water can be collected by placing a pan under the defrost drain located on the exterior bottom front of the cabinet.
7. When defrosting is complete, wash and dry the interior thoroughly. Be sure to replace the plug on the defrost water drain.
8. Reconnect the appliance to the electrical supply and leave running (while empty) for at least 2 hours allowing the interior to cool sufficiently.
9. Replace the previously removed foodstuff.

ATTENTION: A rise in temperature of frozen food products during defrosting may shorten their safe storage life.

CLEANING AND MAINTENANCE

Internal Cleaning

Wash the inside of the appliance with luke warm water and a mild soap. Never use abrasive or corrosive cleaning agents, steel wool, scouring sponges, chemical cleaning agents, or highly perfumed cleaning products to clean the interior as these will damage the surface and leave behind a strong odor. A sponge, towel, or soft brush is recommended. Washing with a mixture of two table spoons of baking soda to 1 quart (1.14L) warm water. After cleaning, thoroughly rinse and dry.

External Cleaning

Wash the outside of the cabinet with warm water and a mild soap or detergent. Do not use abrasive or corrosive cleaning agents, chemical cleaning agents, steel wool or scouring sponges to complete this task as it may cause damage to the surfaces.

END OF LIFE

While this refrigerator should last many year, at some point it will be time to dispose of the unit. Be sure to use normal and proper disposal methods based on your local. When disposing of your appliance, use an authorized disposal site. The refrigerant must be completely drained and collected by an authorized technician for recycling prior to disposal. Check with your local Environmental Agency for recommendations on recycling this appliance in your area. Remove the electrical connection wiring and also ensure that the lid is removed to prevent young children from being trapped inside. **DANGER OF SUFFOCATION!**

HINTS & TIPS

Normal Operating Sounds

- You may hear faint gurgling or bubbling sounds when the refrigerant is pumped through the refrigerant coils.
- When the compressor is on, the refrigerant is being pumped around and you will hear a whirring sound or pulsating noise from the compressor.
- A thermostat controls the compressor and you may hear a 'click' when the thermostat cuts in and out.

Energy Saving Advice

- Do not install the appliance close to sources of heat, such as a stove, boiler, heater, chimney, etc, and avoid exposure of the appliance to direct sunlight.
- Locate the appliance in a cool well-ventilated room and make sure that the air vents of the compressor housing cover are not obstructed. Also allow adequate spacing around the cabinet for air circulation (3in. or 7.5cm)
- Avoid unnecessary frosting in the cabinet by packing all food and liquids in airtight packages or containers.
- Always keep foodstuff stored in tightly sealed packaging or containers, and allow some space for air to circulate around each item.
- Avoid keeping the lid open for extended periods of time or opening the lid too frequently as warm air will enter the cabinet and cause the compressor run unnecessarily often.
- Ensure there are no obstructions preventing the lid from closing properly and forming a tight seal.

TROUBLE SHOOTING

Before contacting a service technician, SunDanzer or your local product dealer, check the following points.

If you call out a technician to a fault listed below, or to repair a fault caused by misuse, abuse, or faulty installation, a charge will be made even if the appliance is under warranty.

SYMPTOM	SOLUTION
Appliance connected to power, but does not operate	<ul style="list-style-type: none">• Check if 12 or 24V DC is present at the appliance. If not check all connections and the system battery voltage.• Check that the polarity is correct “+” is connected to “+” and “-“ to “-“.• Check the fuse. If blown, replace with a new one.• <u>The main common problem with installations is voltage drop to the compressor which causes the unit to fail to start due to “Low Voltage.”</u> Typically, a

	<u>connection is not as tight as it should be, or the wire size to the compressor is too small. The low voltage problem occurs at the instant of start-up and is sometimes difficult to detect with a volt meter because the event is very quick (<100 ms)</u>
Appliance is operating, but the interior is not cold.	<ul style="list-style-type: none"> • Allow the appliance at least 4 hrs from initial turn-on to become cold. • Check that the thermostat control knob is turned to the correct setting relevant to room/ambient temperatures. • Check that the room/ambient temperature is not approaching the internal operating temperature and does not exceed to 100°F (38°C). • Has too much warm foodstuff recently been placed in the cabinet? If so, it is normal to not be cold and it will take time to return to temperature. • Does the cabinet have adequate ventilation around the side walls allowing it to transfer heat properly? (See Installation Section).
The lid will not open.	<ul style="list-style-type: none"> • Has the lid just been opened? If so leave for a few minutes to allow the air pressure to equalize and try again.
Excessive frost and ice has built up.	<ul style="list-style-type: none"> • Is the weather hot and humid? If so, this will increase the rate of frost build up in the cabinet. • Ensure that foodstuff is properly packaged. • Check that the lid is closed and has a good seal, and that nothing is preventing the lid from closing properly. • Large quantities of food have recently been placed in the cabinet/and or the lid is frequently opened. • Ensure that advised periodic cleaning has been carried out.
Noise	<ul style="list-style-type: none"> • Refer to 'Normal Operating Sounds'

CUSTOMER RESPONSIBILITIES

The following items are the responsibility of the customer and are not covered in the warranty:

- Proper care and use of the appliance as described in this manual.
- Damage to the interior or exterior finish or components after delivery.
- Proper power supply, fuse, wiring, and connections.
- Service required as a result of alteration, misuse, abuse, flooding, fire, lightning, or acts of God.
- Replacement of light bulbs.

SPARE PARTS

Please contact SunDanzer with the part description for replacement parts.

- Compressor, PN 101Z0200
- ECU, PN 101N0212
- Thermostat: 007B0028 (Fridge) or 007B0021 (freezer)

WARRANTY

SUNDANZER WARRANTS, TO THE ORIGINAL OWNER, THAT THIS PRODUCT IS FREE FROM DEFECTS IN WORKMANSHIP AND MATERIAL FOR A PERIOD OF TWO YEAR FROM THE PURCHASE DATE. THIS WARRANTY SHALL BE LIMITED TO REPAIRING OR REPLACING, AT SUNDANZER'S OPTION AND WITHOUT CHARGE TO THE PURCHASER, DEFECTIVE COMPONENTS. ALL WARRANTY WORK SHALL BE PERFORMED AT A SUNDANZER APPROVED FACILITY. SHIPPING CHARGES RELATED TO RETURNING THE PRODUCT TO THE SUNDANZER FACILITY ARE NOT COVERED UNDER THIS WARRANTY. HOWEVER, THIS WARRANTY COVERS SHIPPING CHARGES RELATED TO RETURNING THE REPAIRED PRODUCT TO THE CUSTOMER WITHIN THE CONTINENTAL UNITED STATES. OUTSIDE THE CONTINENTAL UNITED STATES, ALL SHIPPING CHARGES ARE THE RESPONSIBILITY OF THE CUSTOMER AND ARE NOT COVERED BY THIS WARRANTY. THIS WARRANTY DOES NOT APPLY TO DAMAGE OR WEAR TO THE PRODUCT CAUSED BY ACCIDENT, ABUSE, MISUSE, NEGLIGENCE, UNAUTHORIZED ALTERATION OR REPAIR, OR IF THE PRODUCT WAS NOT INSTALLED IN ACCORDANCE WITH SUNDANZER PRINTED INSTALLATION AND OPERATING INSTRUCTIONS. TO OBTAIN SERVICE UNDER THIS WARRANTY, THE DEFECTIVE PRODUCT MUST BE RETURNED TO SUNDANZER TOGETHER WITH A RETURN

MATERIAL AUTHORIZATION (RMA) NUMBER. ANY PRODUCT REPAIRED OR REPLACED UNDER THIS WARRANTY WILL BE WARRANTED FOR THE BALANCE OF THE WARRANTY PERIOD WITH RESPECT TO THE ORIGINAL PURCHASED PRODUCT. SUNDANZER WILL NOT BE LIABLE FOR ANY INCIDENTAL OR CONSEQUENTIAL DAMAGES, LOSSES, OR EXPENSES ARISING FROM INSTALLATION, USE OR ANY OTHER CAUSES. THERE ARE NO EXPRESS OR IMPLIED WARRANTIES, INCLUDING MERCHANTABILITY OR FITNESS FOR A PARTICULAR PURPOSE, WHICH EXTEND BEYOND THOSE WARRANTIES DESCRIBED OR REFERRED TO ABOVE.

For warranty claims or additional information, contact:

SunDanzer

420 E Aviation Dr Suite 130
Tucson, AZ 85714, USA
Phone: 915-821-0042
Fax: 775-201-0236
Email: info@sundanzer.com
Website: www.sundanzer.com

Record Product Information:

Model Number:

Serial Number: _____

Purchase Date: _____